

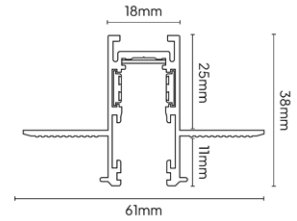

BEFORE YOU START

All operations described in this manual should be performed by a licensed electrician following all the national installation and operation regulations. Please make sure to adhere to the following instructions:

- To prevent electric shock, turn off the electricity at fuse box before installing the tracks, the lighting fixtures and adding or changing accessories.
- Ensure that the electrical (between 0 to 60V DC, max 15A), mechanical and temperature (max 70°C) of the system are always within the reasonable rated range of the system.
- Ensure a distance of 75mm from the lighting fixture to any air ventilation systems and make sure to obey all fire regulations.
- Make sure you don't exceed the maximum distance between mounting points and track load as specified in this document.
- Our Magnet XS track, fixtures, accessories and adapters can not be used with any other parts and systems of other brands and parts without our quality mark.
- The different types of connectors can only be used for the corresponding track parts as specified in this document.
- Do not touch the installed lighting fixtures when in use.
- Do not cover the lighting fixture by any material at any time.
- According to the EU Directive WEEE (Waste Electrical and Electronic Equipment) the luminaire must not disposed of via inserted waste. It must be sent to the respective local facility for disposal and/or the recycling of electronic products.



Track size

If non original parts and accessories are used or the installation is not in accordance with the provided installation instructions, Keylight cannot be held responsible for the safety and functionality of the system.

OFFICIAL MAGNET XS TRACK SYSTEM PARTS & ACCESSORIES



Track Recessed 2000mm



Track Recessed 3000mm



Blind Cover



End Cap



Power Feed



Corner Connector set



Inside Corner Connector set



Straight Connector



Flexible Corner Connector

MAXIMUM MOUNTING DISTANCE & MAXIMUM TRACK LOAD

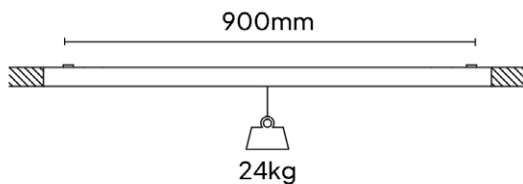

Maximum track load with mounting points no more than 900mm apart

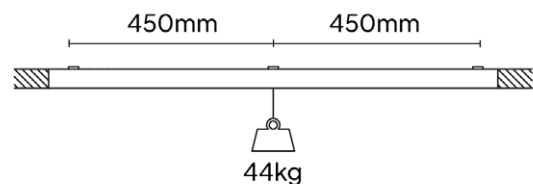

Maximum track load with mounting points no more than 450mm apart

RECESSED TRACK INSTALLATION

1

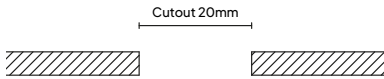

Cut out the needed space for the recessed tracks to fit into the ceiling.

2

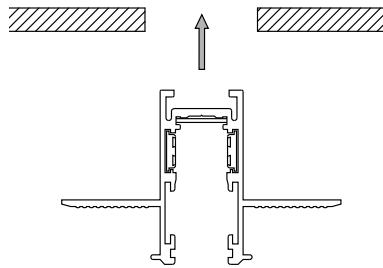

Insert the recessed tracks into the ceiling and keep in place.

3

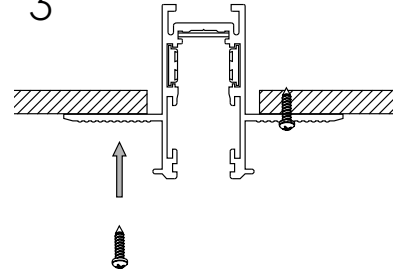

Use appropriate screws to secure the track onto the ceiling at the correct mounting distance.

4

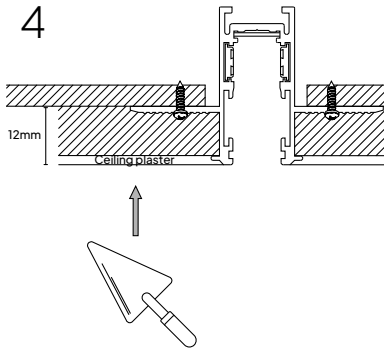

Integrate seamlessly into the ceiling with plasterboard and finish with ceiling plaster.

CONNECTING MULTIPLE TRACKS

1

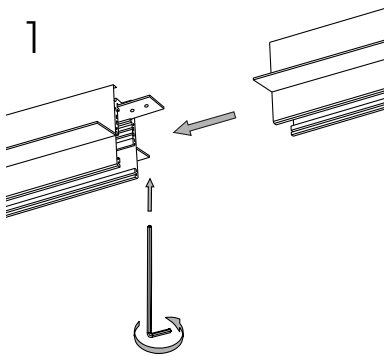

Connect two Magnet XS tracks with the connecting bracket and tighten hex screws to secure.

2

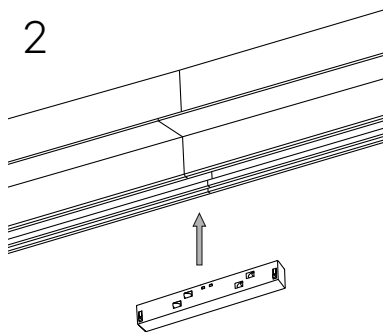

Insert straight connector or flexible connector to transfer power between tracks.

3

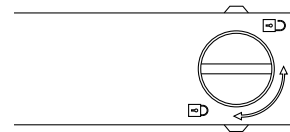

Don't forget to lock the power feed to ensure it is locked into place.

CONNECTING TRACK CORNERS

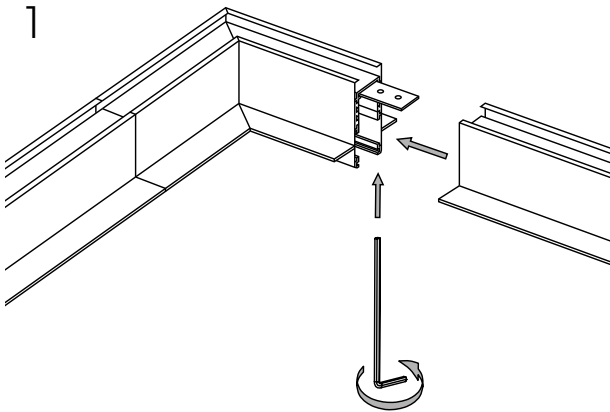

Connect two straight track pieces together with the corner piece and tighten the hex screws to secure.

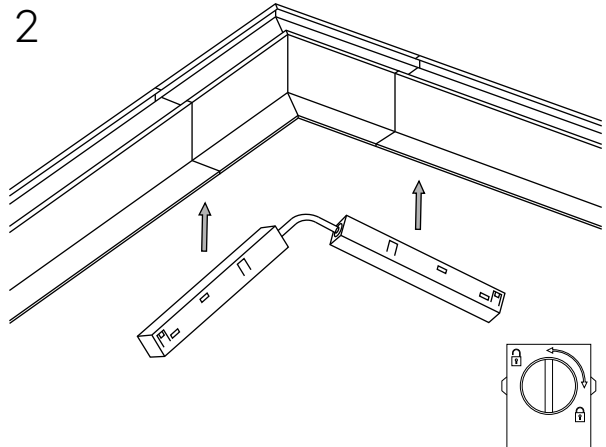

Insert the flexible connector into the corner and lock the connector to secure it.

CONNECTING 48V EXTERNAL DRIVER ON/OFF

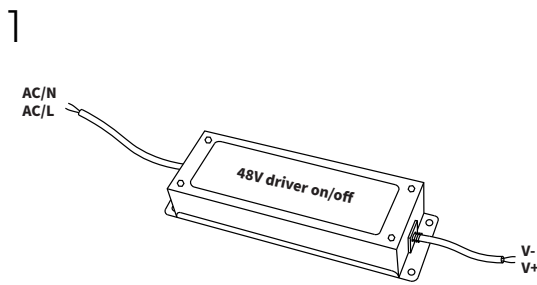

Driver is placed somewhere outside of the track and connected directly to power mains and Magnet XS Track Power Feed.

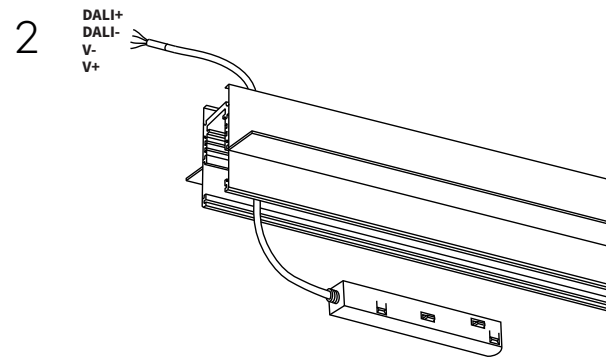

Connection schedule for Magnet XS Track Power Feed. DALI line is not used.

CONNECTING 48V EXTERNAL DRIVER DALI

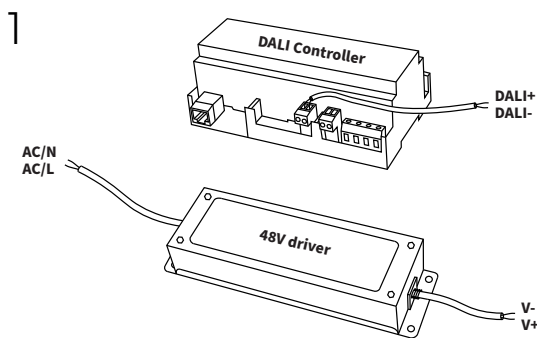

Driver is placed somewhere outside of the track and connected directly to power mains and Magnet XS Track Power Feed. DALI line is connected to DALI controller/router.

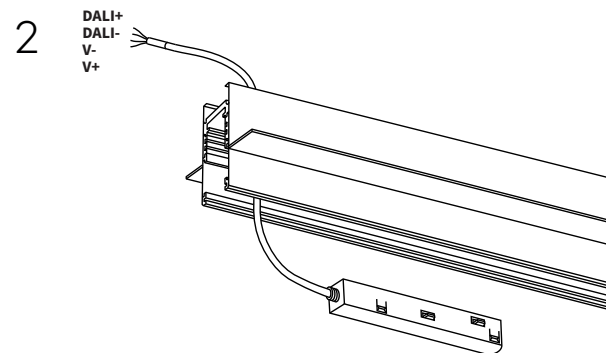

Connection schedule for Magnet XS Track Power Feed.